

Thank you for choosing the Vandersteen Model Seven Reference Loudspeaker System. While the grilles are removable, we recommend that you leave them on the speakers at all times. The Model Sevens were engineered and measured with their grilles in place. Removing the grilles compromises the performance of the speakers and exposes the drivers to possible damage from probing fingers. For a complete understanding of the Model Seven's innovative technology and unique features we recommend that you review this entire manual before connecting or using your new speakers.

Vandersteen Audio

The Model Seven combines the superior openness and realism of the legendary Vandersteen boxless design with the powerful, extended bass of an amplified subwoofer in a compact and elegant loudspeaker. Unique features optimize the Model Seven for a wide variety of placements, environments, and system configurations. It is available in any automotive finish to complement any décor.

The Model Seven incorporates advanced patented Carbon Fiber/Balsa sandwich cones and domes for the midbass, midrange and tweeter. This technology allows true piston operation for each driver in its pass-band, allowing very low distortion and uniformity in sound. This innovation offers

incredibly transparent reproduction because all drivers from 100Hz and above are made of the same material with exactly the same characteristics. These very stiff diaphragms allow for dynamic contrast unheard of with typical materials. On the rear input plate are eleven room compensation controls that a qualified technician uses to match the low frequencies to the listening room, and level and contour controls that allow you to tailor your Model Sevens to your own personal taste.

The Vandersteen Model Seven is designed and built in the United States of America.

VANDERSTEEN MODEL SEVEN REFERENCE LOUDSPEAKER OPERATIONS MANUAL

Unless the high-pass crossover is built into the electronics, (See page 3.) the Model Seven system requires a M5-HP crossover between the preamplifier and main power amplifier that is matched to the input impedance of the power amplifier. Using the speakers without a properly configured M5-HP in place will severely damage the midbass drivers. The drivers in your Model Sevens are critically paired to within one tenth of a dB. In most cases if one driver is damaged, the pair must be replaced. Physical damage (probing fingers) or damage due to a missing or improperly configured M5-HP crossover will require non-warranty replacement of two very expensive drivers. (Minimum \$480.00 per pair for the tweeters alone.)

CONTENTS

SETTING-UP	2	Listening Height	11	SW Amplifier Replacement	16
The M5-HP Crossover	2	Plugging-In The SW Amp	11	Crossover Replacement	16
High-Pass Electronics	3	LF Room Optimization	12	Removing the Grille	16
The Speaker Cables	4	Controls	12	Driver Replacement	17-18
Bi-Wire Connections	5	Amplifier Requirements	13	Troubleshooting	18
Vertical Bi-Amp Connections	6	MAINTENANCE	15	Common Questions	18
Internal Bi-Wire Connections	7	Cleaning	15	Support	18
Speaker Placement	8	Service	15	PACKING INFORMATION	19
Installing The Cones	11	Battery Replacement	15	WARRANTY	20

SETTING-UP THE MODEL SEVEN

Unless the high-pass crossover is built into the electronics, (see page 3) the M5-HP crossover is required in all systems. Using the speakers without a properly configured M5-HP crossover in place will cause severe and costly non-warranty damage to the midbass drivers.

True balanced amplifiers will have the same impedance value on the positive and negative legs of the inputs. An amplifier with different impedance values on the positive and negative legs of the inputs is not truly balanced and is not compatible with the balanced version of the M5-HP crossover.

THE M5-HP CROSSOVER

The Model Seven uses a unique crossover and subwoofer amplification configuration to provide the true benefits of bi-amplification and reduce the current demands on the main amplifier. By inserting a passive high-pass crossover between the preamplifier and the main

amplifier then connecting the Model Sevens like conventional bi-wired speakers, the main amplifier remains in the signal path to the subwoofer, but its current demands are reduced. This insures sonic continuity as the main amplifier's characteristics that are evident through the upper frequencies are maintained to the deepest bass, but with the power and control of the Model Seven's internal 400 watt amplifier.

The M5-HP is the high pass crossover for the mid-bass driver and must be installed in the system between the pre-amplifier and power amplifier before the Model Sevens are used. (The only exception is in systems with a high-pass amplifier as noted below.) Properly configured to match the input impedance of the amplifier, the M5-HP will roll off the low frequencies going to the amplifier so that they are -3db at 100Hz referenced to 1kHz. To compensate for the low-frequency roll-off induced by the crossover, the response of the Model Seven's amplifier is contoured to restore the low frequencies to the proper level as shown in the illustrations to the left. The M5-HP is a totally mono design, two are required for a stereo pair of Model Sevens. M5-HPs are available in both balanced and single ended configurations to match any system.

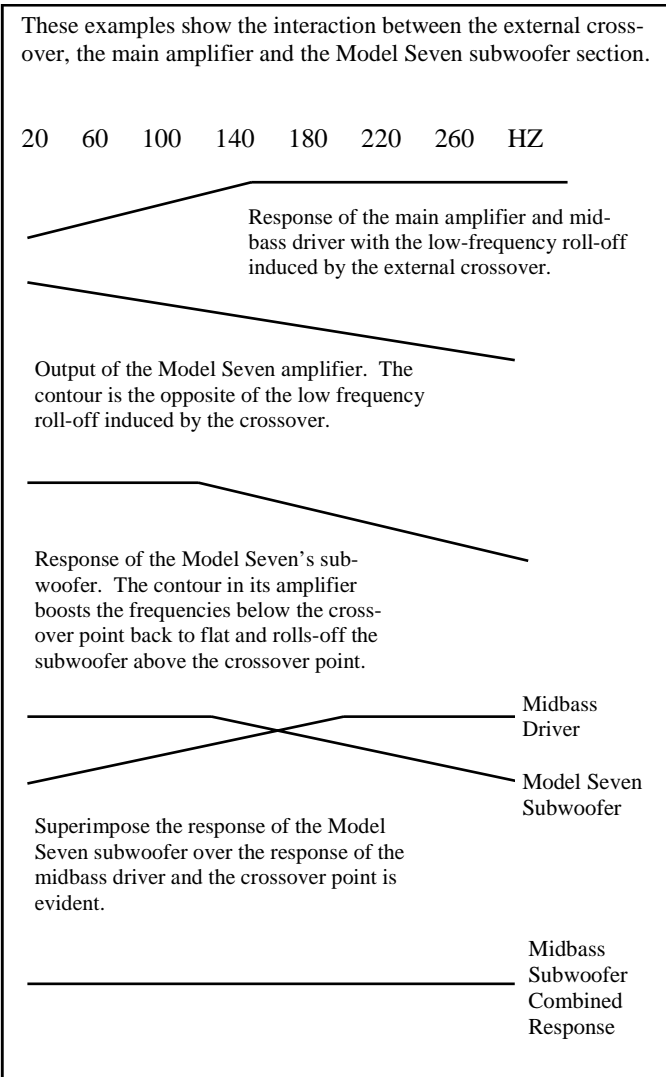

CONFIGURING THE M5-HP CROSSOVER

Before you use the M5-HPs, each unit's internal set of ten dip switches must be set to match the input impedance of your main amplifier. Information on your amplifier's input impedance should be in its manual or available from its manufacturer. **If you do not have accurate information on your amplifier's input impedance, do not use your Model Seven speakers until you get the information or have a competent technician determine the input impedance by the method described on the next page.** With balanced amplifiers, the M5-HP crossover must be set to match the sum of the positive and negative legs of the input. (The individual legs must each be exactly one half the impedance.) If the individual legs do not both have the same

impedance, the amplifier must be used in single-ended mode or with a complex, custom crossover the amplifier's manufacturer may be able to provide.

To set the M5-HPs in either a balanced or single ended system, please follow these procedures.

1. Locate the value closest to the input impedance of your amplifier in the chart located on the top cover of the M5-HP. If your amplifier's input impedance is between values, use the lower value. Note which switches to turn on to match the input impedance value.
2. Remove the cover from an M5-HP and locate the internal set of ten dip switches.
3. Turn on the switches listed for the value you found. The numbered side is "ON". A switch is on when it is depressed on the side of the numbers.
4. Repeat the procedure for the second M5-HP. Reinstall the covers.

If you are unable to find the amplifier's input impedance or if you are not completely sure you have the correct input impedance, you should have a competent technician at your dealer determine the proper setting for the M5-HPs by the following method.

1. Connect a signal generator to the input of an M5-HP crossover, the output of the M5-HP to the input of

your main amplifier and the output of the amplifier to an oscilloscope as shown in the diagram below.

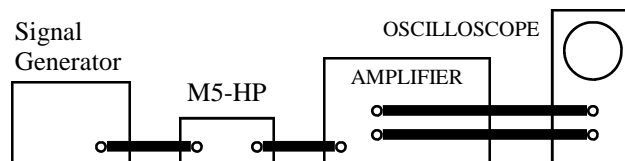

2. Set the M5-HP's internal dip switches for 50k impedance value as noted on the chart. If the -3db down point is above 100Hz, try a lower setting. If the -3db down point is below 100Hz, try a higher setting. When the -3db down point is at 100Hz, the M5-HP is set to match your amplifier. (If the oscilloscope is not calibrated in db, find the setting where the voltage at 100Hz is .707 of the voltage at 1kHz.) This setting is the input impedance of your amplifier. It is a good idea to write it down for future reference.
3. Set the second M5-HP to the same setting.

The M5-HP contains a battery that continuously biases some of its components. The battery is mounted on the PC board and has a life expectancy of 7+ years. Please do not attempt to measure the output of the battery as the measurement process will drain the battery more than several months of normal use. Written on each battery is the year that it should be replaced to insure continuous optimum performance.

INSERTING THE M5-HP INTO THE SYSTEM

1. Connect the outputs from the properly configured M5-HPs to the inputs of the main amplifier.
2. With a high-quality cable, connect the left channel preamplifier output to the input of the M5-HP that is connected to the left channel of the main amplifier.
3. With a high-quality cable, connect the right channel preamplifier output to the input of the M5-HP that is connected to the right channel of the main amplifier.
4. In multi-channel systems, insert the M5-HP between the processor L&R outputs and the amplifier inputs.

HIGH-PASS PREAMPLIFIERS, AMPLIFIERS AND MULTI-CHANNEL PROCESSORS

Some preamplifiers, power amplifiers, integrated amplifiers and multi-channel processors can be configured by the user or the manufacturer to provide the low-frequency roll-off required by the Model Sevens. Incorporating the high-pass crossover into the system electronics eliminates the need for M5-HP crossovers.

The high-pass section of the applicable unit must be configured to these specifications:

Frequency Response: -3db at 100Hz
6db per octave (First order)

As you set up your Model Sevens, you will be prompted several times to evaluate some aspects of their performance with reference quality music recordings. We find that natural instrument jazz recordings generally offer the most realistic and accurate sonic reproductions. They are usually of a small group yet cover a wide frequency range. Most are straight through recordings with a minimum of processing or acoustical manipulation. If you are not really familiar with these types of recordings, your Vandersteen dealer and/or other experts can help you select some. Once you have established your reference recordings, you can maintain consistency by using these recordings to evaluate all component, wire and placement changes. Without reference recordings, it is easy to fall into the trap of trying to retune the system for every different recording.

CONNECTING THE SPEAKER CABLES

SELECTING SPEAKER CABLES

Research has demonstrated that the speaker cables must be considered an integral part of the music system. Each brand and model of cable has its own sonic characteristics and contributes to the overall presentation of the music as much as any active component. The Model Seven easily passes the amount of information required to hear these differences between cables.

There is no one best cable to use with the Model Sevens. To assure that they were sonically neutral, the Model Sevens were developed using a direct-coupled laboratory amplifier connection loaded by precision resistors to simulate cable resistance. With neutral speakers, the factors that determine the best cables for your system are your personal taste, the characteristics of your listening room, and the associated equipment. The only person familiar enough with your taste and room characteristics to assist you in selecting cables is someone from your local dealer who has visited your room and sat through listening sessions with you. No one else can adequately evaluate two of the three factors (taste and room).

If you wait to select the cables until the other components in the system are set, you can fine-tune the system with your cable choice. As you evaluate different cables in your system, remember that the dielectric in most quality cables takes several hours to fully form. These cables may not reach their full potential or exhibit their true sonic characteristics until they have been in the system for a week or more.

It is very important to keep the speaker cables as short as possible. In repeated trials, short runs of inexpensive to moderately priced cable consistently outperformed long runs of the same cable as well as much more expensive cables. If you must place your speakers a long distance from your electronics, you should consider positioning the amplifier between the speakers and using long interconnect cables with short speaker cables. With comparable lengths and quality, long interconnect cables seem to compromise the sound of a system less than long speaker cables. An additional advantage is that a given length of interconnect cable will usually cost less than the same length of bi-wired speaker cable. An amplifier placed between the speakers can easily be concealed by a plant or placed in a decorative piece of furniture.

BI-WIRING

The Model Sevens are optimized for true bi-wiring using two separate speaker cables to connect each speaker to the amplifier. The speaker's internal crossover presents different electrical characteristics to each cable so that one cable carries the signal going to the woofers while the other cable carries the signal going to the midrange and tweeter. The improvements offered by bi-wiring versus a conventional single run of cable are

substantial. Often, a bi-wire set of moderately priced cables will sound better than a single run of far more expensive cables.

All the speaker cables in a bi-wire set should be the same type. While it is tempting to use a cable known for good bass response on the low frequencies and a different cable known for good treble response on the midrange and tweeter, the differing sonic characteristics of the two cables can affect the blending between the midbass and midrange drivers and compromise imaging, transparency, and detail. Different cables should only be used after you audition them in your system and verify that they do not affect the midbass to midrange blending and that you like their sonic characteristics.

Our research revealed that much of bi-wiring's benefit comes from the physical separation of the low frequency cable from the midrange/tweeter cable. Internal bi-wire cables that combine all the wires together in one sheath do not offer all the advantages of true bi-wiring. These multiple conductor cables are the only recommended method of mono-wiring the speakers, but should not be considered the equivalent of dual cable bi-wiring.

BI-AMPLIFICATION

The Model Sevens can only be bi-amplified passively with two identical stereo amplifiers in a vertical configuration. (One stereo amplifier per speaker.) Since a single, higher quality amplifier will usually sound better than two lesser amplifiers, we only recommend bi-amplification when every component in the system is the best available and there is no other path to improving the system. Caution should be used when bi-amping as some amplifiers will oscillate on transients resulting in speaker failure especially the tweeter.

When vertically bi-amplifying, the speaker's internal passive crossover will divide the signal between the midbass and the midrange/tweeter by presenting different electrical characteristics at different frequencies to each channel of the amplifier. Above approximately 200Hz, this type of passive filter is the most transparent method of dividing the signal between the drivers. The internal passive crossover between the midbass and midrange can not be bypassed so an electronic crossover can not be used to bi-amplify the Model Sevens. Two crossovers in series with each other (electronic and passive) cause severe phase shift and response non-linearities.

The Model Sevens should not be bi-amped with two different amplifier models in a horizontal mode. (One amplifier driving the low frequencies and the other amplifier driving the midrange and tweeter.) When half of the speaker is driven by a different amplifier model than the other half - and in these cases, usually by amplifiers chosen

for the differences in their sounds rather than the similarities — the blending between the midbass and midrange drivers is compromised and the sonic consistency of the speaker is effected. The upper and lower ranges of the speaker exhibit

different dynamic characteristics, tonal balances, and detail through the frequency range where the human ear is most sensitive to inconsistencies.

Bare wires should never come into contact with the aluminum dress plate while the amplifier is on. Amplifier damage could result.

The input screws should be snug, but should not be over tightened.

TRUE BI-WIRE CONNECTIONS

True bi-wiring is recommended for all systems using a single stereo amplifier or two mono amplifiers. Four identical runs of equal length speaker cables are required. (Two per speaker.)

Please review the information on page 4 regarding cable selection and connection techniques before you connect your speakers.

1. Crimp and solder spade lugs to the speaker ends of the cables being used to connect the Model Seven.
2. Choose one of the cables as the tweeter/midrange cable. Connect this cable to the two terminals on the right carefully observing proper polarity.
3. Connect the remaining cable to the two left terminals carefully observing proper polarity.
4. Connect both cables in proper polarity to the same set of outputs on your amplifier. If possible, use a single spade lug to connect both positive wires and a single spade lug to connect both negative wires to the amplifier as shown in the diagram to the right.

WE RECOMMEND

- a. All four speaker cables should be the same type and length. While certain different cable types may work well together, using identical cables on both inputs insures perfect blending.
- b. Use high quality cables and spade lugs. Crimp and solder the spade lugs to the cables.
- c. If your amplifier has “A” and “B” outputs, use the “A” outputs for both cables. The two sets of outputs may not be electrically identical.
- d. If your amplifier has multiple impedance taps, try the 4 ohm taps and 8 ohm taps to see which sound better. (They will sound different.) The Model Seven is an easy load and always stays between 4 and 8 ohms so there is no danger of damaging your amplifier or the speakers by using either set of taps. Both cables must be connected to the same rated taps on the amplifier.

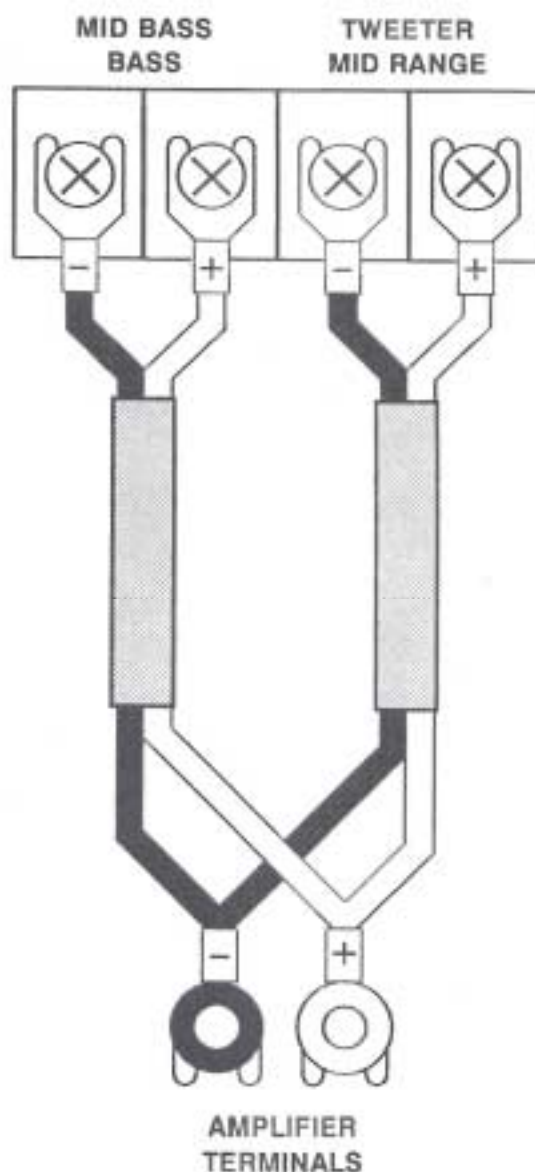

VERTICAL BI-AMP CONNECTIONS

We only recommend bi-amplification when every component in the system is the best available and there is no other path to improving the system. In all other cases, you are better off investing in the best single amplifier. Caution should be used as some amplifiers will oscillate using this configuration with possible speaker damage.

Vertical bi-amplification uses a stereo amplifier to drive each speaker. Four identical runs of equal length of speaker cables are required. (Two per speaker.)

Please review the information on page 4 regarding cable selection and connection techniques before you connect your speakers.

1. Connect two cables to each speaker as described in steps 1-3 on the previous page.
2. Designate one stereo amplifier as the left channel amplifier and the other identical stereo amplifier as the right channel amplifier.
3. Connect the preamp's left channel output to both in-puts of the left amplifier using two sets of pre-amplifier outputs and two cables or one cable and a high quality single female to dual male "Y" connector. Use the same method to connect the pre-amplifier's right channel output to both inputs of the right amplifier. The M5-HP must be connected to one channel of each amplifier.
4. Connect the bass cable from the left speaker to the channel of the left amplifier where the M5-HP crossover is connected. Connect the tweeter/midrange cable from the left speaker to the other channel of the same amplifier. Verify proper polarity.
5. Connect the bass cable from the right speaker to the channel of the right amplifier where the M5-HP crossover is connected. Connect the tweeter/midrange cable from the right speaker to the other channel of the same amplifier. Verify proper polarity.

WE RECOMMEND

- a. Verify with the amplifier manufacturer that your amplifiers are the same generation and sound the same.
- b. If your amplifier has multiple impedance taps, try the 4 ohm taps and 8 ohm taps to see which sound better. (They will sound different) The Model Seven is an easy load and always stays between 4 and 8 ohms so there is no danger of damaging your amplifier or the speakers by using either set of taps. Both cables must be connected to the same rated taps on the amplifier.
- c. All four speaker cables should be the same type and length. While certain different cable types may work well together, using identical cables on the top and bottom insures perfect blending.

The input screws should be snug, but should not be over tightened.

Bare wires should never come into contact with the aluminum dress plate while the amplifier is on. Amplifier damage could result.

This connection method can only be used in a system configured with two identical stereo amplifiers.

VERTICAL BI - AMP

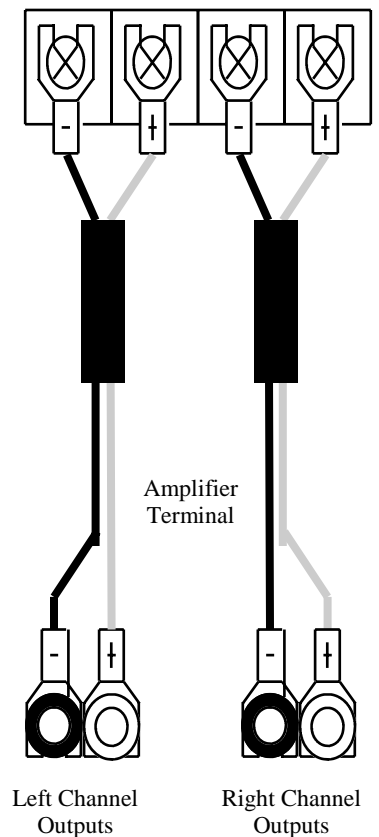

Bare wires should never come into contact with the aluminum dress plate while the amplifier is on. Amplifier damage could result.

The input screws should be snug, but should not be over tightened.

While single-cable internal bi-wiring is the only recommended method of mono-wiring the Model Sevens it does not offer all the performance advantages of true bi-wiring.

INTERNAL BI-WIRE, or Mono Wire CONNECTIONS

If your domestic situation dictates the use of a single cable per speaker, you should use a multiple conductor single-sheath cable to internally bi-wire the speakers. Some of these cables use different types of wire for the upper and lower ranges of the speaker and may effect the blend between the midbass and midrange drivers. They should only be used after you audition them in your system and verify that they do not effect the midbass to midrange blending and that you like their sonic characteristics.

Please review the information on page 4 regarding cable selection and connection techniques before you connect your speakers.

1. Crimp and solder spade lugs to the speaker ends of the cable from the amplifier.
2. Connect one positive and one negative wire to the tweeter/midrange terminals on the right carefully observing proper polarity.
3. Connect the remaining positive and negative wires to the two left terminals carefully observing proper polarity.
4. Connect the wires in proper polarity to the same set of outputs on your amplifier. If possible, use a single spade lug to connect both positive wires and a single spade lug to connect both negative wires to the amplifier as shown in the diagram to the right.

WE RECOMMEND

- a. The speaker cables should be as short as possible and the same length. Consider putting the amplifier between the speakers rather than off to one side.
- b. If your amplifier has multiple impedance taps, try the 4 ohm taps and 8 ohm taps to see which sound better. (They will sound different.) The Model Seven is an easy load and always stays between 4 and 8 ohms so there is no danger of damaging your amplifier or the speakers by using either set of taps. Both cables must be connected to the same rated taps on the amplifier.
- c. True bi-wire for optimum performance.

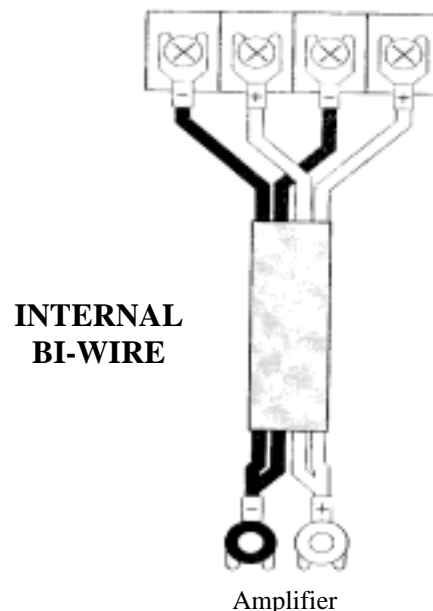
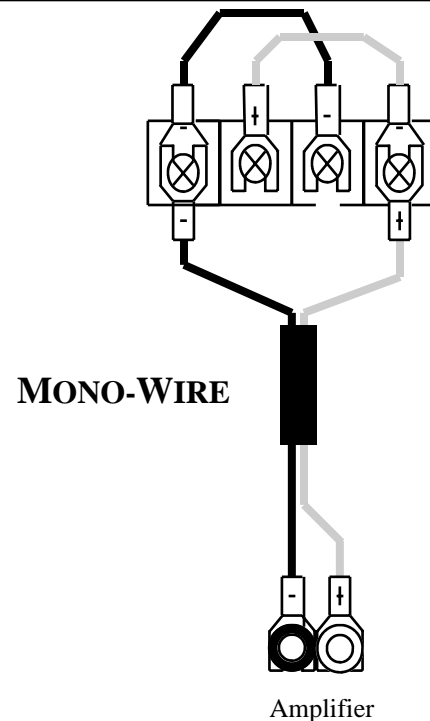

With their extensive subwoofer controls and room compensation adjustments, the Model Seven's low frequency response can be optimized for any placement. The speakers' positioning will effect the midbass, midrange, and treble performance with some positions offering better imaging and superior frequency balance and detail. With the tremendous variables in room construction and layout, there are no magical formulas for determining the best speaker placement in every room. We recommend that you try the speakers in every domestically acceptable location to find their best midbass to treble performance in your particular listening environment. The odd dimensions placement method covered in the following sections is a tool that can help you find an acceptable placement, but to find the optimum placement, you will need to invest the time and effort to try all the possible placements in the room.

Before you begin your positioning experiments, verify that the speakers are connected to the amplifier in proper polarity and that the M5-HP crossover is in place and properly set for the input impedance of the amplifier. The cones should not be installed. Set the speakers on flat cookie sheets so that they will easily slide on the carpet from position to position. To insure that the bass performance of different placements does not bias your judgment of the midbass, midrange, and treble, all placement experiments should be performed with the subwoofer amplifier unplugged.

Carefully listen to the imaging and midbass to treble performance of each possible placement with your reference quality music recordings. Without the subwoofer sections, the speakers will have the frequency balance of high-quality mini-monitors and should be evaluated as such. Listen for detail, clarity, naturalness, and the overall presentation of the music. Keep notes on the different placements to help track where the speakers sound the best, once found use tape and mark rear cone location.

SPEAKER PLACEMENT

When you place a given loudspeaker, either front radiating or dipole, into a typical domestic environment, the room effects the performance of the speaker. Some of these effects are due to the speaker's relationship to the physical dimensions of the room and can be significantly effected by placement. Every distance from the source of sound (drivers) to a boundary (wall) has an effect. Odd dimensions placement assures that no two boundary effects build on each other.

ODD DIMENSIONS PLACEMENT

A method that helps find possible placements in many rooms is positioning the loudspeakers on the odd dimensional intersections of the room. The odd dimensional intersections are where lines representing the length and width of your room divided by odd numbers would cross.

As an example, we will use a rectangular room measuring 14 feet wide by 18 feet long. We'll assume that you want to set the speakers on one of the short walls, although this method works equally well for long wall placement.

The first step is to take the length of the room, (18 feet in our example) convert it from feet to inches, ($18 \times 12 = 216$) and divide the result by odd numbers.

216 divided by 3 is 72 (all to the nearest inch)

216 divided by 5 is 43

216 divided by 7 is 31

216 divided by 9 is 24

216 divided by 11 is 20

(and so on; eventually the lines pile on top of each other or the speaker gets too close to the wall to access the rear connections and controls.)

The results are the distances in inches that the top front

center of the speaker's grille frame should be away from the wall behind the speaker.

Now we can graph these odd dimension distances on a drawing of the room. We only need to graph them for the wall where we intend to place the speakers.



We use the same method to figure how far the top front center of the speaker's grille frame should be from the side walls. We take the width of the room, (14 feet) convert it from feet to inches, ($14 \times 12 = 168$) and divide the result by odd numbers.

- 168 divided by 3 is 56 (all to the nearest inch)
- 168 divided by 5 is 34
- 168 divided by 7 is 24
- 168 divided by 9 is 19
- 168 divided by 11 is 15

The results of these odd number divisions are the distances in inches that the top front center of each speaker's grille frame should be away from the side wall.

Now we can graph these odd dimensions distances on a drawing of the room.

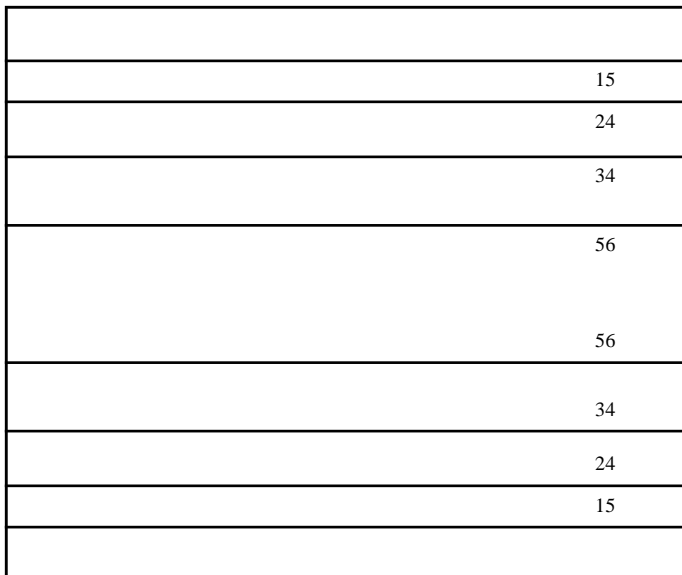

By overlaying the width and length graphs, we can see the intersection points of the lines. These points represent

where the top front centers of the speakers' grille frames should be.

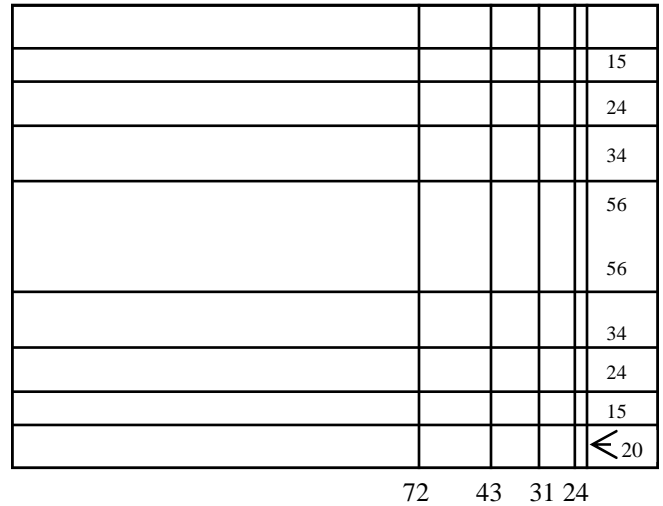

As you can see, we now have quite a few intersections to choose from in our example room. In your room, some of the intersections will be impossible to try or eliminated due to domestic considerations.

As you try different placements for your speakers, always place both speakers on the same length line. For example, both speakers would be placed on 43 inch line or both speakers would be placed on the 24 inch line. The speakers can be placed on different width lines, for example one on the 34 inch line and the other on the 56 inch line. Placing the speakers on different rather than matching width lines will require that the listening position be offset to center it between the speakers. Often the imaging will be better with the speakers placed on matching width lines.

After listening to the speakers centered on the charted intersections, you should listen with the speakers a few inches away from the intersection points in each direction. In some cases, the speakers will sound better slightly off the intersections due to the particular characteristics of your room or a slight error in your original room measurements. Both speakers should be moved the same amount forward or backward to maintain a consistent listener to speaker distance when fine-tuning placement.

Several factors influence how speakers interface with a room other than the room's basic dimensions so it is possible that none of the placement options on the wall you initially place the speakers on will sound quite right. The sound may be too forward or too withdrawn or the imaging may not be to your liking. If you are unable to achieve satisfactory sound with the speakers placed on one wall, try placing the speakers on a different wall of the room. Even in a rectangular room, the speakers will interface differently with the room depending upon which of the four walls they are placed. In some rooms the speakers will sound best placed on a short wall, while in other rooms the speakers will work better on a long wall.

ACOUSTICAL CENTER

The Model Seven's acoustical center is at the top front center of the grille frame. In a perfectly rectangular room with absolutely rigid walls and no doors or windows, the acoustical center of the loudspeaker would be placed exactly at the point where the two dimensions intersect to realize the full benefits of odd dimensions placement. In a real room, the actual best placement may vary from the intersection by several inches. Fine-tuning the placement by moving the speakers a few inches off the calculated intersections takes these real world conditions into account.

You should not use any placements that put the acoustical center of the loudspeaker the same approximate distance from the rear and side walls or where one distance is a multiple of the other. In our example room, this would eliminate the intersection of the 24 inch width and length lines since they are both the same distances from their respective walls. It would also eliminate the intersection of the 24 inch width line and 72 inch length line because 72 is a multiple of 24. ($3 \times 24 = 72$) If any of the odd dimension intersections in your room are within a few inches of being the same distance from the side and rear walls or multiples of each other, you should not use them.

SPEAKER TOE-IN

The degree of toe-in can effect the imaging and response characteristics of the speakers. In most rooms, the speakers will work well with twenty degrees of toe-in. Speakers that are placed close to the side walls or in rooms with very reflective side walls may require additional toe-in to avoid a confused image and/or a forward midrange and treble. Although rare, in some rooms the speakers may actually perform better with a slight amount of toe-out.

ACOUSTIC TREATMENTS

If the speakers are close to the side walls and you hear a brightness in the midrange/treble or a problem with the imaging that toeing-in the speakers does not help, some sound diffusers should be mounted on the side walls to control reflections.

To determine where the sound diffusers should be placed, imagine that the walls are mirrors and mount them on the walls where you would see the reflections

of the speakers when you are sitting in your normal listening position. Before you actually mount anything on the side walls, experiment with the diffusers location to verify that you will get the results you desire.

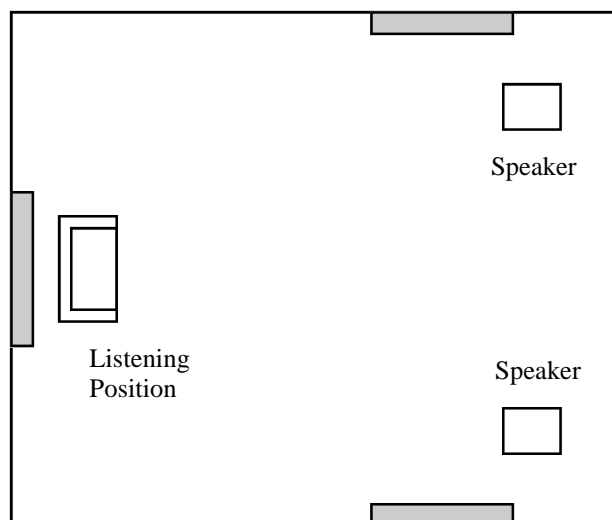

If your listening position is close to the wall behind you, mount some sound absorbent material, such as a hanging tapestry, directly behind your head. As with the diffusers for the side walls, experiment with a pillow or a folded natural-fiber blanket to verify the results before you acquire or mount the material.

HELPFUL HINTS

- A. To try the speakers on different walls, set your equipment in the middle of the room so the speaker cables can reach each possible location.
- B. When you change the placement of the speakers, listen to several different reference quality music recordings before judging the results of the change.
- C. If you set the speakers on a wood floor, use spike shoes to protect the floor from damage.
- D. Don't over-analyze the sound of each placement. When the sound is right, it will be obvious.
- E. Keep notes on the sound of different placements you try. It is easy to get mixed-up and forget which placement sounded the best.

The Model Sevens break-in and significantly improve during the first 100 hours of use. Until this period has elapsed, the speakers exhibit some sonic aberrations as the parameters of the Model Seven were established with completely broken-in drivers.

INSTALLING THE CONES & LISTENING HEIGHT ADJUSTMENTS

The Model Seven is supported by three cones, one in each front corner and one in the rear center. Install the skirted locking collar on the cone and thread the cone in until the bottom of the skirt is even with the top of the cone (this should leave about seven threads showing on top of the locking collar). With the speakers still in the position previously discovered, thread the cone assemblies directly into the bottom of the speaker with the top of the locking collar just touching the bottom of the speaker and the bottom of the skirt still even with the top of the cone. Do not tighten them at this time. At no time should the weight of the speaker be on the cones with less than seven threads into the speaker bottom. Two people are required to safely install the cones. Do not attempt to install the cones by yourself.

All properly aligned loudspeakers have a vertical listening window where their sound is optimized. The Model Seven's six inch high optimum listening window is centered at 36 inches when the speaker is vertical. If your ear height is above or below 36 inches at your normal listening position, the speakers should be tilted to center the optimum listening window at your ear height. A Laser Jig is used to level, set vertical alignment and toe in .

1. Remove the grille and install the Laser Jig into the four grille receptacles on the front baffle. Make sure the Jig is seated into the receptacles fully.
2. Measure the ear height of the listener relaxed in the listening position. Place a piece of cardboard vertically against the seat back. Draw a X on the cardboard at ear height exactly on center (this will be slightly behind the ears which is OK). With a level for a straight edge draw a plumb vertical line through the X.
3. Rotate the laser to the earlier determined toe on the protractor. Tip: when measuring for speaker location determined by the earlier experiment, use tape to mark the precise position for the rear cone of each speaker. All toe movements will swivel on the rear cone so the speaker position remains constant. Turn on the laser and rotate the speaker until the dot falls on the vertical line. Turn off the laser.
4. Using the bubble level built into the Laser Jig, level the speaker (right-left) using the front cones. Insert a small

PLUGGING-IN THE SUBWOOFER AMPLIFIER

With the speaker cables connected, the M5-HP crossover in place, the placement established, and the cones installed, the Model Seven's subwoofer amplifier should be plugged-in. The amplifier uses a removable power cord that should be securely inserted into the amplifier then plugged into a non-switched outlet that is known to be operating properly. If an extension cord is required, it should be as short as

Improper listening height can cause the speakers to sound extremely bright or dull.

Two people are required to safely install the cones. Do not attempt to install the cones by yourself.

Be careful not to cross thread the cones as you install them into the bottom of the Model Seven. The cones should turn easily by hand. Damaged threads can be repaired with a 9/16x18 thread tap. A stuck cone can be removed by turning it with a nail or small screwdriver inserted through the cross hole.

- screwdriver into the cross hole in the cone and turn in the cone (counter clockwise) on the high side until level. Do not turn either cone clockwise as the cones are already out as far as allowed. Holding the cone in place with the screwdriver, tighten the locking collar with the supplied wrench on both front cones. Double check that there are no threads showing on either cone.
5. Turn on the laser and verify that the dot is still on the vertical line. Tweak if necessary. With a screwdriver into the cross hole of the rear cone, turn it in (counter clockwise) until the dot is on the X. Tighten the locking collar. The Model Seven is now perfectly aligned.
 6. Remove the grille from the other speaker and install the Laser Jig.
 7. Rotate the laser to the same but opposite angle on the protractor and repeat steps #3 through #5. Both Model Sevens are now perfectly aligned.

possible and constructed of 14 gauge or larger wires. As the amplifier is plugged-in, it will usually produce a thump or pop from the subwoofer. Never use a ground cheater.

During electrical storms or when the system will not be used for a long period of time, (i.e. vacations) the Model Seven amplifier should be unplugged along with the other components in the system.

The Model Seven amplifier levitates the subwoofer cone and centers the voice coils. If the subwoofer amplifier has been unplugged for more than a few hours - including when the speakers are first set-up - avoid playing deep bass above a moderate conversational level until the amplifier has been plugged-in for at least one hour to allow the subwoofer driver to center. Never float the subwoofer ground!

LOW-FREQUENCY ROOM OPTIMIZATION

The eleven room compensation controls located on the rear input plate help counter the amplitude and phase effects of room nodes and anti-nodes and provide the most linear low frequency response at the listening position. They can only be properly set by using the Vandertones disk and a Radio Shack analog S.P.L. meter. Once the controls have

been set for a particular room, they should not need to be readjusted unless the speaker placement and/or listening position are significantly changed.

The low-frequency level will be set by the process on page 13.

ADJUSTMENT SECTION WITH VANDERTONES DISK AND RADIO SHACK S.P.L. METER

This procedure requires the Radio Shack analog S.P.L. meter (digital will not give satisfactory results) and the Vandertones test disk. Do not use any

of the commonly available frequency correction charts or a meter that has been modified to be corrected.

GUIDE TO ADJUSTING THE ROOM COMPENSATION CONTROLS.

1. Set the microphone at the listening position at ear height.
2. Turn on the S.P.L. Meter to the 70dB scale, "C" weighting, "Slow" response.
3. Insert Vandertones test disc into a CD player, set the volume on the preamp to a low level.
4. On the left Model Seven sub-woofer amplifier set the low frequency contour control to minimum (#1) and verify that all eleven room compensation bands are set straight up (screwdriver slot vertical). Set low frequency level to 0dB.
5. Locate the Low Frequency Work Sheet provided loose in this manual. Make copies if necessary and keep one as a master.
6. Play tracks one through eleven (left channel) and note on the Work Sheet the meter readings for all eleven tracks. Adjust the preamp volume up or down until two thirds of the tracks read 70dB or higher and one third of the tracks are 70dB or lower. This is your reference volume. Do not readjust until this entire calibration is complete for both speakers.
7. Play tracks one through eleven again and note on the Work Sheet how far each band is above or below 70dB. For example:
dB 0 +4 -10 +10 +6 -4 +10 +3 +6 -6 +3
(Note: that two thirds are up and a third are down. If the reading is off the scale, call it +10 or -10).
8. Play tracks sixteen through twenty six (right channel) and verify two thirds are above 70dB and one third below. It most likely will not be, so adjust the low frequency level on the right speaker's amplifier up or down until two thirds are above and one third are below. Do not change this setting until finished with the calibration procedure. Note: this is on the right speaker not the preamp which remains as set earlier.
9. Play tracks sixteen through twenty six again and note on the Work Sheet how far each band is above or below 70dB. For example:
dB +6 -3 -4 0 +4 +10 +2 +6 +10 -3 +2
(Note: that two thirds are up and a third are down. If the reading is off the scale, call it +10 or -10 as before).
10. Calculate the target correction by multiplying by .3 and rounding to the next greater whole number. For example using the right channel noted above:
dB +2 -1 -2 0 +2 +3 +1 +2 +3 -1 +1
(Note: if the pot stops full counter clockwise or clockwise before attaining your target number this is OK, leave it there do not force the pot as they are fragile).
11. Repeat #10 for the target calculation for the left channel.
12. Play track one and have an assistant adjust pot #1 on the left speaker to the previously calculated target or all that is possible within the range of the pot.
13. Repeat #12 for each appropriate track and pot.

14. Play tracks sixteen through twenty six and have an assistant adjust pots #1 through #11 as before. For your information the bands center frequencies are:
- | | | | | | | | | | | | |
|------|----|----|----|----|----|----|----|----|----|-----|-----|
| Pot# | 1 | 2 | 3 | 4 | 5 | 6 | 7 | 8 | 9 | 10 | 11 |
| Frq. | 20 | 24 | 30 | 36 | 42 | 50 | 60 | 72 | 84 | 100 | 120 |
15. This procedure is half art and half science so do not try to adjust every peak or dip all the way to 0dB even if possible. Our studies and listening have shown that adjusting all the peaks and dips to 0dB can cause a non-musical sound with audible equalization effects. Some rooms are very flat and the temptation to adjust for perfectly flat will be great. Don't do it, as it will sound over equalized. Our ear/brain knows there are standing waves in the room and can't be fooled so all we can do is reduce their amplitude. If after finishing the final level and contour adjustments in the section below you feel the sound is not engaging, go back and carefully relax the corrections made. Start by backing

off any pot that was at maximum or minimum rotation about one hour, as if it were a watch face.

Note: In most rooms because the surroundings are not symmetrical it is quite common for the right and left Level Control on the bass amplifier to be at different settings. This is true even in rooms where the speakers are placed symmetrically because of adjacent rooms or wall construction differences. It is important for this difference to remain when adjusting the sub-woofer Level Control in the following section. For example: the left Low Freq Control is at "0" because that is what the calibration procedure calls for and the right Low Freq Level may have ended up at "+2" during the calibration procedure of the right speaker. This differential must always remain. We have calibrated dozens of rooms over the years and have observed that the bass change is minimal but the midrange becomes noticeably more open and three dimensional.

If after finishing the final level and contour adjustments in the section below you feel the sound is not engaging, go back and carefully relax the corrections made. Start by backing off any pot that was at maximum or minimum rotation about one hour, as if it were a watch face.

Do not try to set the Room Compensation Controls by ear. Due to the complex interactions of the controls, you will only succeed in compromising the inherent accuracy of the speakers. Unless adjusted using the preceding method, the eleven Room Compensation Controls should be left straight up.

LOW-FREQUENCY LEVEL

Set the low-frequency contour control to minimum (#1) and verify that all 11 room compensation bands are set up. Select a clean jazz recording with a stand-up bass scaling up and down. Adjust the Low-Frequency Level controls

on the speakers until the transition from the subwoofer to the upper part of the speaker is seamless and linear. The levels on both speakers should maintain any difference discovered during Room Compensation adjustments.

CONTOUR AND HIGH-FREQUENCY LEVEL CONTROLS

Three controls on the Model Seven's input plate allow you to tailor the characteristics of the speaker's bass and treble response to suit the listening environment and your personal taste. The High-Frequency Level and High-Frequency Contour controls adjust the output level and response characteristics of the rear mounted tweeter while the Low-Frequency Contour control adjusts the Q of the subwoofer section. Since these controls alter the performance of the speaker to match your personal taste, they should be adjusted by ear using well recorded, accurate jazz recordings. All the instructions for adjusting these controls assume that the Low-Frequency Room Compensation controls have been set, and the Low-Frequency Level adjusted for linear response. It is also assumed that

the speakers are positioned according to previous instructions, that the cones are installed with the tilt required to aim the speakers at your listening height and that the high-pass crossover is in place and properly configured.

Before we individually address each of these controls and their use, we want to point out that they are not substitutes for tone controls. One should be careful to select known high quality recordings with recognizable instruments to eliminate confusion and the possibility of chasing variations in recordings. This could be like watching a cat chase its tail! A good jazz recording with a stand up bass works best. Preamplifier tone controls are designed to withstand thousands or even tens of thousands of adjustments and are the best way to compensate for

your particular tastes and the peculiarities of individual recordings. The Model Seven's controls were chosen solely for their sonic characteristics and have a life expectancy of hundreds rather than thousands of uses. This should be enough to cover several lifetimes worth of residence changes or room alterations.

LOW-FREQUENCY CONTOUR (Q CONTROL)

The Low-Frequency Contour control adjusts the Q of the subwoofer to accommodate different rooms, listening tastes, or system modes. In subwoofer engineering terms, system Q is the product of a complex mathematical equation derived from driver, electrical, and enclosure parameters. In practical terms, it relates to the character of the bass response. A low Q subwoofer sounds very tight and controlled. A high Q subwoofer produces a warm, full bass with more energy in the most audible bass range.

The Model Seven's Low-Frequency Contour control is leveled from 1 to 10. As shown in the graph below, position # 1 provides the tightest bass (Lean Audiophile Sound), position # 7 is maximally flat as measured at the driver cone, (Linear Anechoic Response) and position # 10 emulates the peaked response of a typical high Q home theater subwoofer (Big and Boomy.)

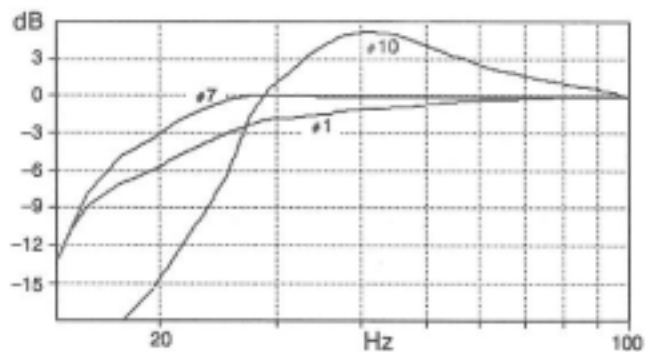

Once the room compensation controls have been set by a qualified technician, our experience is that the bass in most rooms sounds the most linear on high-quality music recordings with the Low-Frequency Contour set in the # 5 to # 8 range. Contour should always be the same for both speakers. Please remember that every room and system are different and that the nominal position in your system may be higher or lower due to room characteristics or personal preferences.

Once you have established the nominal setting for your system, we recommend that you make any temporary bass adjustments with the preamplifier's or video processor's bass controls. If your system does not have tone controls and is regularly used for home theater reproduction, we recommend using an additional one or two V2W L.F.E. theater subwoofers. The Low-Frequency Contour control should be set to the best setting for two channel music as described above. With this configuration the Model Seven's sub-woofer and the L.F.E. sub-woofer(s) will be in play while watching movies. Fun!!!

HIGH-FREQUENCY LEVEL AND CONTOUR

The High-Frequency controls adjust the output level and response characteristics of the rear mounted tweeter. As you prepare to set the rear tweeter for your room and taste, there are some points you should consider. In most rooms, with the speakers positioned reasonable distances from the walls, the best setting for the rear tweeter is OFF. With the rear tweeter turned off, the Model Seven is a perfectly aligned, mono-polar design. Our measurements as well as our ears convince us that this configuration provides the best imaging, the most true detail, and the lowest distortion. In some highly damped rooms however, speakers with flat treble response can sound dead and lifeless. We believe that in these rooms, increasing the high-frequency content of the reverberant field is the best way to compensate for the extreme room characteristics.

The decision to incorporate the rear tweeter into the Model Seven was not an easy one. Even though it can produce some pleasing phasey phenomena as its output reflects 901 different ways off the surrounding walls, it is a second source for the information reproduced by the direct tweeter and therefore, its contribution to the sound field is significantly smeared in time and technically 100% distortion. (The front direct tweeter is already reproducing all of the high-frequency information on the recording, any increase above what is actually on the recording is by definition, distortion.)

In highly-damped rooms with thick carpeting, plush furniture, and heavy drapes, activating the rear tweeter may subjectively provide a more realistic and lifelike frequency balance. If you decide to use the rear tweeter, set the High-Frequency Level control at # 3 and evaluate the different High-Frequency Contour settings with your reference recordings to determine which contour settings sound the most natural in your room. Each higher number extends the rear tweeter's output slightly lower in frequency as shown in the graph below.

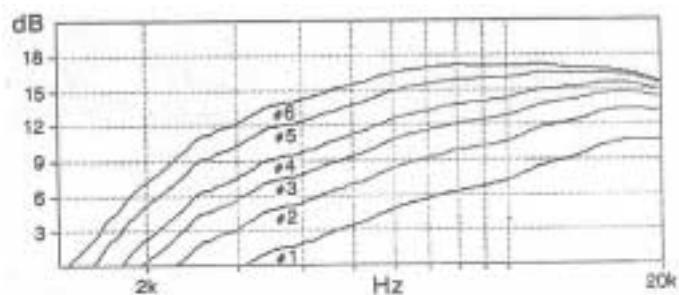

After you decide which contour setting provides the best high-frequency characteristics for your room, use the High-Frequency Level control to adjust the rear tweeter level. Each higher number increases the output of the rear tweeter by about 11/2dB.

If you are unable to achieve satisfactory performance using the information and procedures above, please contact the Model Seven Customer Assistance Department at Vandersteen Audio.

AMPLIFIER REQUIREMENTS

The Model Seven is designed for use with amplifiers rated from 30 to 200 watts per channel into 8 ohms. These amplifiers will provide ample power for realistic listening levels in most situations. Amplifiers with less than 75 watts should be tested with the volume control half the way up (the point where most amplifiers clip) to verify that the system can achieve realistic listening levels without stress. Amplifiers with more than 200 watts must be used with caution due to the increased potential for speaker damage if they are misused or an accident occurs.

The Model Sevens are very revealing speakers and are easily capable of showing the subtle sonic differences between amplifiers. They will perform well with a tube, transistor, or hybrid amplifier, allowing each design to realize its full potential.

Fuses between the amplifier and the Model Seven will degrade the performance of the entire system. No fuses are used in the Model Seven and preference should be given to the use of an amplifier that does not use output fuses.

Preamplifiers and CD players should be left on except during electrical storms or extended absences. Amplifiers should be turned off when the system is not being used. Once broken in, modern power amplifiers sound good after only 20 minutes of warm-up. Leaving the amplifier on all the time exposes the speakers to possible damage from power line anomalies or electrical component failure while the system is unattended.

MODEL SEVEN MAINTENANCE

CLEANING

The appearance and performance of the Model Seven can be enhanced by observing a few precautions and performing some simple maintenance.

The input terminals on the Model Seven and the spade lugs on the speaker wire should be cleaned periodically with alcohol or a solution made specifically for cleaning electrical contacts. Other connection points in the system should be cleaned as per the equipment manufacturer's recommendations.

The grille cloth on the Model Seven can be gently

vacuumed using a brush attachment that will not snag the cloth. The automotive finish should be cleaned with a damp soft cotton cloth (old T shirt). The polyurethane clear coat can be maintained with an occasional coat of car wax, being careful not to get it on the grille fabric. Do not use Windex or any product with ammonia on the Model Seven.

The speakers should not be exposed to excessive heat or direct sunlight which can damage the fit and finish of the fine finish.

SERVICE

In the unlikely event that your Model Sevens require service, please follow these procedures.

1. Verify that your Model Sevens have been set-up and connected according to the instructions in this manual.
2. Verify that the problem you are hearing is in the speaker by switching the left and right speaker cables at the speakers. If the problem switches sides, it is in a component or cable rather than the speaker.
3. Play each bass input and the midrange/treble input of the suspect speaker separately to determine which section has a problem.
4. Contact Vandersteen Audio with your Model Sevens serial number, information on your associated components, a description of the problem and the steps you have taken to isolate it to the Model Seven.

5. The Model Seven is a modular system. Should Vandersteen Audio determine that a module needs to be returned to the factory for repair, a Return Authorization form is available on our website. (Due to the precise driver matching, drivers may need to be replaced in pairs).
6. Return the damaged or defective module and the completed Return Authorization Form to Vandersteen Audio. Any shipment of a complete Model Seven to the Factory will be refused.

VANDERSTEEN AUDIO
116 West Fourth Street
Hanford, CA 93230
(559) 582-0324
www.vandersteen.com

BATTERY PACK REPLACEMENT

The Model Seven contains an internal battery pack that continuously biases some of the crossover components. The battery pack is mounted on the crossover board and has a life expectancy of 12+ years. Like all Model Seven components, the battery pack should be changed at the factory (remove the entire cross over).

Please do not attempt to measure the output of the

battery pack. The measurement process will drain the batteries more than several months of normal use.

You should contact your dealer or Vanderstee Audio regarding changing the battery packs. Date of Change:

If you do not feel you have the technical expertise to disassemble and reassemble the speaker modules, you should have your Vanderstee dealer or a competent technician perform the work.

REMOVING THE SUBWOOFER AMPLIFIER MODULE

1. Turn off the main amplifier. Unplug the subwoofer amplifier.
2. Remove the speaker cables.
3. Remove the screws securing the aluminum input plate. Remove the input plate.
4. Place a stack of books at the rear of the speaker to support the amplifier as it is removed. The support stack should be just a little below the bottom of the amplifier heat sinks.
5. Remove the screws holding the amplifier.
6. Carefully pull the amplifier back and rest it on the stack of books.
7. Using a thin blade screwdriver through the square opening at the top of the amp, loosen the set screws holding the input wires and gently pull the input wires loose.
8. Loosen the screws on the output terminals and remove the four output wires.
9. Pull the amplifier completely clear of the speaker and set it on a soft surface.

REINSTALLING THE SUBWOOFER AMPLIFIER MODULE

1. Place a stack of books at the rear of the speaker to support the amplifier as it is reconnected. The stack should be just a little below the amplifier cavity in the speaker.
2. Reconnect the four output wires. As you look at the amplifier with the transformer at the bottom, the wires from left to right are red, red with green band, black, black with green band.
3. Reinsert the input wires into the terminals and tighten the set screws. The red wire should be inserted into the terminal toward the outside edge of the amplifier.
4. Being careful not to pinch the wires, insert the amplifier into the speaker and attach it with its screws.
5. Reinstall the aluminum input plate.

REMOVING THE CROSSOVER MODULE

1. Remove the subwoofer amplifier according to the instructions in the earlier section.
2. Remove the eight silver screws attaching the eyelets to the terminal block.
3. Remove the two screws from the vertical portion of the PC board.
4. Pull on the crossover board with a steady force so that it slides out the rear of the speaker.

REINSTALLING THE CROSSOVER MODULE

1. Gently slide the crossover board into its tracks until it stops.
2. Insert the two screws into the vertical portion of the PC board.
3. Insert the eight silver screws attaching the eyelets to the terminal block.
4. Reinstall the subwoofer amplifier according to the instructions in the earlier section.

REMOVING THE GRILLE STRUCTURE

1. Grab with your fingers the left and right sides of the upper portion of the grill just above the lower section. Wiggle the grill assembly back and forth but straight out. Do not pry or pull on the lower section.

2. Once the four grille receptacles release, carefully continue to move the assembly straight out until clear of the speaker enclosure. The upper and lower sections are

bonded together and will wedge into a bind if not kept straight.

3. Set the grille assembly in a safe place where it will not be damaged or soiled.

REINSTALLING THE GRILLE STRUCTURE

1. Carefully align the grille with its appropriate sockets and gently tap the grille at all four corners of the upper section. Use caution and keep the grille assembly square with its recess around the woofer.
2. Tap all four corners progressively until completely seated. Note: if you try to insert the lower section ahead of the upper section the grille assembly will be damaged or the finish will pop off the corners.

REMOVING THE SUBWOOFER DRIVER

1. Unplug the subwoofer amplifier, and disconnect the speaker wires.
 2. With the assistance of at least one other person, gently lay the speaker down on one side on a soft surface that you are certain does not contain any hidden debris that could scratch the finish. Support the speaker so there is no movement while working.
 3. Remove the screws holding the black bottom on the speaker. (You do not need to remove the cones.)
- Set the bottom to the side where it will not be damaged or soiled.
4. Cut the wires to the outside voice coil as close to the terminals as possible.
 5. Remove the lock nuts securing the subwoofer driver. Carefully pry the driver out.
 6. Cut the wires to the inner voice coil as close to the terminals as possible. Make a note of wire color and any markings on the driver for polarity.

REINSTALLING THE SUBWOOFER DRIVER

1. With the solder provided with the rebuilt or replacement driver, solder the wires to the terminals for the inner voice coil in the proper polarity noted earlier.
2. Install the driver into the cabinet and secure it with the lock nuts. (The nuts should be snug, do not over tighten them.) An air-tight seal is required. If the existing weather stripping is not in good shape, peel it off and replace it with new weather stripping available from Vandersteen Audio.
3. Solder the wires to the terminals for the outer voice coil in the proper polarity.
4. Install the bottom on the speaker and secure it with the screws. (The single cone should be located at the rear of the speaker.)
5. With another person's help, set the speaker upright and reconnect the speaker cables, and plug-in the subwoofer amplifier.

REMOVING THE MIDBASS DRIVER

1. Remove the grille structure.
2. Remove the screws securing the driver.
3. Carefully pry the driver out.
4. Cut the wires as close to the terminals as possible. Note the color of the wire and any special markings of polarity for future use.

REMOVING THE MIDRANGE DRIVER

1. Remove the grille structure.
2. Remove the screws mounting the tweeter. Pull the tweeter and have a assistant hold it being careful to not put too much strain on the wires.
3. Remove the screws securing the midrange driver.
4. Carefully pry the driver out.
5. Cut the wires as close to the terminals as possible. Temporarily replace the tweeter and hold it in place with one screw.

REMOVING THE TWEETER DRIVER

1. Remove the grille structure.
2. Remove the screws that are around the outside of the face plate. Do not touch the three screws forming the inner circle.
3. Cut the wires (white with black and red markers) as close to the terminals as possible but not the black and green wires coming from the square module.
4. The tweeter will be serviced with the module.

REINSTALLING A DRIVER IN THE SPEAKER HEAD

1. With the solder provided by Vandersteen Audio with the replacement pair of matched drivers, solder the wires to the driver terminals in the proper polarity. (Apply the heat to the wire. When the solder flows to the terminal, quickly pull the soldering pencil away.

This will avoid heat damage to the driver terminal's plastic parts.)

2. Install the driver into the cabinet with its screws.
3. Reinstall the grille structure.

TROUBLESHOOTING GUIDE

Problem: Subwoofer driver hums. Audible at the listening position.

Solution: Try different grounding methods. Try floating the main amplifier's power cord with a cheater. Never float the ground on the Model Seven power cord. Attach a ground wire from the ground terminal (near IEC connector) to the preamp.

Problem: Still hums, grounding changes didn't help.

Solution: Check your interconnect cables. Route cables away from the amplifier. Position the M5-HP crossover away from the amplifier. Verify that the M5-HP is properly installed in the system. Try the system at a very low volume level without the M5-HP. If the M5-HP is the source of the hum, it will have to be replaced before the system can be used.

Problem: Still hums, cable and crossover changes didn't help.

Solution: Disconnect the inputs from the Model Seven, if the hum is still evident at the listening position, please contact Vandersteen Audio. (It is normal for the amplifier's high-voltage

power supply to have a slight hum but this should not be audible more than a few feet away from the speaker.)

Problem: No subwoofer output.

Solution: Verify that the Model Seven subwoofer amplifier is plugged into a live AC outlet. (It should thump or pop when you plug it in.) Verify that the AC cord is securely inserted into the Model Seven's amplifier.

Problem: High or low subwoofer output level.

Solution: Verify the actual input impedance of the main amplifier and that the M5-HP is correctly matched to it. Check the low-frequency level and contour control settings.

Problem: Model Seven amplifier excessively hot.

Solution: Remove the amplifier according to the instructions on page 16 and return it to Vandersteen Audio for service.

Problem: Unsatisfactory high-frequency balance.

Solution: Check the high-frequency level and contour control settings.

COMMON MODEL SEVEN QUESTIONS

Can a subwoofer or subwoofers be added to a system with Model Sevens?

The Model Sevens contain integral subwoofers and there would be no benefit or advantage to adding separate subwoofers. When the Model Sevens are used in a home theater system, program the processor to redirect the Low Frequency Effects (LFE) and subwoofer information to the front channels where it will be reproduced by the Model Seven subwoofers. Some may want to add an LFE sub.

What speaker cables sound best with the Model Seven?

The cables that sound best with your Model Sevens are the cables that are most complementary to your particular associated equipment, the characteristics of your room

and your personal taste. There is no way for us to adequately evaluate two of the three deciding factors, (room and taste) so there is no way for us to accurately predict what cables will sound best with your Model Sevens.

How will I know when an update is available for my Model Sevens?

Vandersteen dealers will be notified when Model Seven updates are available. In most cases, the update will be performed by the factory. Some updates may be available to the original owners only. The only way to prove this is by registering the warranty or keeping the original invoice.

SUPPORT

This manual has dealt with the installation, use, and capabilities of Vandersteen Model Seven loudspeakers. You should review this manual with anyone who will use the audio system to insure that they will exercise proper care and judgment.

Should you have any questions regarding your Model Sevens, you should contact Vandersteen Audio by phone M-F 8:00am to 5:00pm Pacific Time. We will do our best to answer your questions and address your concerns.

UNPACKING AND REPACKING THE MODEL SEVEN

At least two people are required to unpack or pack a pair of Model Sevens. Each speaker is shipped on its own pallet and has a gross weight over 220 pounds. Please use the handholds in the boxes and proper lifting techniques to lift and move the speakers.

There could be grease or dirt on the bottom of the pallet. Cover carpet with several layers of newspaper or an old blanket before you set the pallet down.

The speaker must remain up-right as it is unpacked. Do not tilt the pallet to access the securing bolts or remove the box.

UNPACKING INSTURCTIONS

1. Cut the tape around the top of the box at all four corners.
2. Lift up each of the top flaps to release the main box flaps that were anchoring the top in place and lift the top off.
3. Lift the cardboard grille cover/spacing collar up and off the speaker.
4. Cut the tape around the bottom of the box at all four corners.
5. Pull out the bottom flaps to release the main box

flaps that were holding the bottom and the main box together and lift the main box up and off the speaker.

6. Lift the plastic bag and flannel sock off the speaker.
7. With allen wrench provided, reach through the opening in the pallet and remove the two bolts attaching the speaker to the pallet.
8. With the help of at least one other person, lift the speaker off the pallet and set it on a soft surface. Do not use the grille frame to support the speaker.

REPACKING INSTURCTIONS

The Model Seven must be bolted to its pallet and properly packed in its original box prior to shipment.

1. With one person supporting the body of the speaker, carefully lean the speaker to the sides and remove the cones from the bottom.
2. Gently lift the speaker and set it on the pallet inside the cardboard recess.
3. Insert the two shipping bolts with washers through the pallet and into the speaker. Tighten the bolts just one turn past finger tight.
4. Pull flannel sock and the plastic bag over the speaker.
5. Slide the main box down over the speaker. Secure the main box flaps inside the bottom flaps as shown in the illustration. Run reinforced tape around the bottom to hold the flaps tight against the box.
6. Slide the grille cover/spacing collar over the speaker.
7. Place the top on the box and secure the main box flaps inside the top flaps as shown in the illustration. Run reinforced tape around the top to hold the flaps tight against the box.

Please keep the boxes, pallets and hardware. Replacement boxes and pallets must be shipped by truck and will cost at least \$450.00

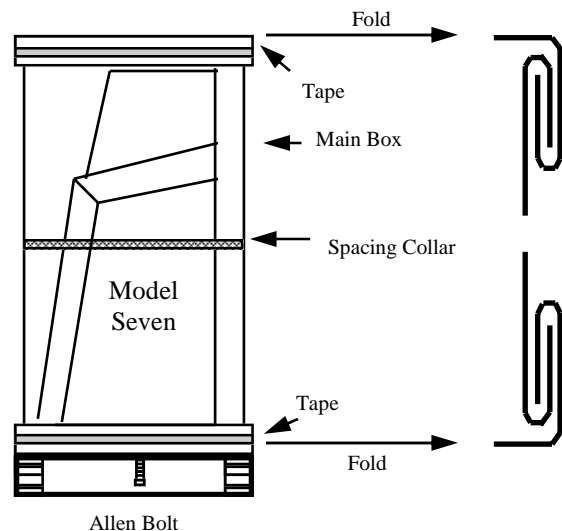

LIMITED ONE YEAR WARRANTY

VANDERSTEEN AUDIO loudspeakers are warranted to the original purchaser to be free from defects in materials or workmanship, SUBJECT TO THE FOLLOWING CONDITIONS, for one (1) year from the date of purchase from an authorized VANDERSTEEN AUDIO dealer.

THIS WARRANTY IS SUBJECT TO THE FOLLOWING CONDITIONS AND LIMITATIONS:

This warranty is void and inapplicable if the loudspeaker has:

- A. Not been used in accordance with the instructions contained in the operation manual.
- B. Been subject to misuse or abuse; examples of which would be burned driver voice coils or burned crossover components.
- C. Been modified, repaired, or tampered with by anyone not specifically authorized to do so by Vandersteen Audio.
- D. Been subject to inputs in excess of the maximum rating, or inputs from an unstable or clipped amplifier.
- E. Suffered physical damage to the structure or components due to accident, neglect, or transportation.

IF A VANDERSTEEN AUDIO LOUDSPEAKER FAILS TO MEET THE ABOVE WARRANTY AND THE ABOVE CONDITIONS HAVE BEEN MET, THEN THE CUSTOMER'S SOLE REMEDY SHALL BE TO RETURN THE PRODUCT TO VANDERSTEEN AUDIO WHERE THE DEFECT WILL BE REPAIRED WITHOUT CHARGE FOR PARTS OR LABOR. THIS WARRANTY APPLIES ONLY TO PRODUCTS RETURNED TO VANDERSTEEN AUDIO IN HANFORD, CA USA.

(Returning the product to Vandersteen Audio from some countries other than the United States may involve considerable time and expense. The customer is responsible for all fees and duties and for providing instructions and all the paperwork required to return the product after it is serviced.)

The speaker must be packed in the original packing and returned to VANDERSTEEN AUDIO via insured freight by the customer at his or her own expense. A returned product must be accompanied by a Return Authorization Form, (available from VANDERSTEEN AUDIO upon request) which includes a written description of the defect and return shipping information.

ANY IMPLIED WARRANTIES RELATING TO THE ABOVE PRODUCT SHALL BE LIMITED TO THE DURATION OF THE ABOVE WARRANTY. THIS WARRANTY DOES NOT EXTEND TO ANY INCIDENTAL OR CONSEQUENTIAL COSTS OR DAMAGES TO PURCHASER.

Some states do not allow limitations on how long an implied warranty lasts, or an exclusion of incidental or consequential damages so the above limitations or exclusions may not apply. This warranty gives you specific legal rights, you may also have other rights in your state.

VANDERSTEEN AUDIO reserves the right to modify the design of any product without any obligation to previous purchasers and/or to change the prices or specifications without notice or obligation to anyone.

A PERSONAL NOTE

I have been doing volunteer work for several years with elderly people with severe hearing losses, and I have seen the frustration and anger that are brought on by these losses. We now know that many of these people developed their hearing problems because of exposure to high noise levels when younger.

Many home stereo systems, as well as audio/video, personal, and automobile sound systems are capable of volume levels potentially damaging to your hearing. Please use common sense, and listen to your music and movies at safe levels now so you will still have the ability to hear and enjoy them in the future.

Richard Vandersteen